

USB3.0 HD Video Conferencing Camera

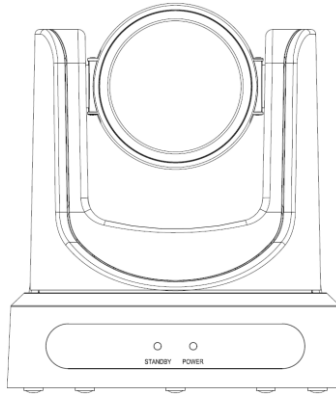

User Manual

V1.1

(English)

Preface

Thanks for using this USB3.0 HD Video Conferencing Camera.

This manual introduces the function, installation and operation of the HD camera. Prior to installation and usage, please read the manual thoroughly.

Precautions

This product can only be used in the specified conditions in order to avoid any damage to the camera:

- Don't subject the camera to rain or moisture.
- Don't remove the cover. Otherwise, you may get an electric shock. In case of abnormal operation, contact the authorized engineer.
- Never operating under unspecified temperature , humidity and power supply.
- Please use the soft dry cloth to clean the camera. If the camera is very dirty, clean it with diluted neuter detergent; do not use any type of solvents, which may damages the surface.

Note:

This is class A production. Electromagnetic radiation at the specific frequency may affect the image quality of TV in home environment

Contents

Note.....	3
Supplied Accessories	4
Quick Start	5
Features.....	8
Product Specification	9
Main Unit.....	12
Size.....	13
IR Remote Controller Explanation	14
USE IR Remote Controller	17
RS-232 Interface	20
VISCA Network Configuration	21
Serial Communication Control	22
VISCA Command List.....	23
Menu Setting.....	24
Internet connection(Only the network models).....	29
USB3.0.....	39
Maintenance and Troubleshooting.....	40

Note

- **Electric Safety**

Installation and operation must accord with electric safety standard.

- **Caution to transport**

Avoid stress, vibration and soakage in transport, storage and installation.

- **Polarity of power supply**

The power supply of the product is +12V, the max electrical current is 2A .Polarity of the power supply plug drawing as follows.



- **Careful of installation**

Do not grasp the camera head when carrying the camera. Don't turn camera head by hand. Doing so may result in mechanical damage.

Don't apply in corrosive liquid, gas or solid environment to avoid damaging the cover which is made up of plastic material.

To make sure no obstacle in rotation range.

Never power on before installation is not completed.

- **Don't dismantle the camera**

We are not responsible for any unauthorized modification or dismantling.

CAUTION!

The specific frequency of electromagnetic field may affect the image of the camera!

Supplied Accessories

When you unpack, check that all the supplied accessories are included:

Camera 1PCS

AC power adaptor 1PCS

Power cord 1PCS

RS232 cable 1PCS

Remote controller..... 1PCS

User manual 1PCS

USB3.0..... 1PCS

Quick Start

Step1. Please check connections are correct before starting

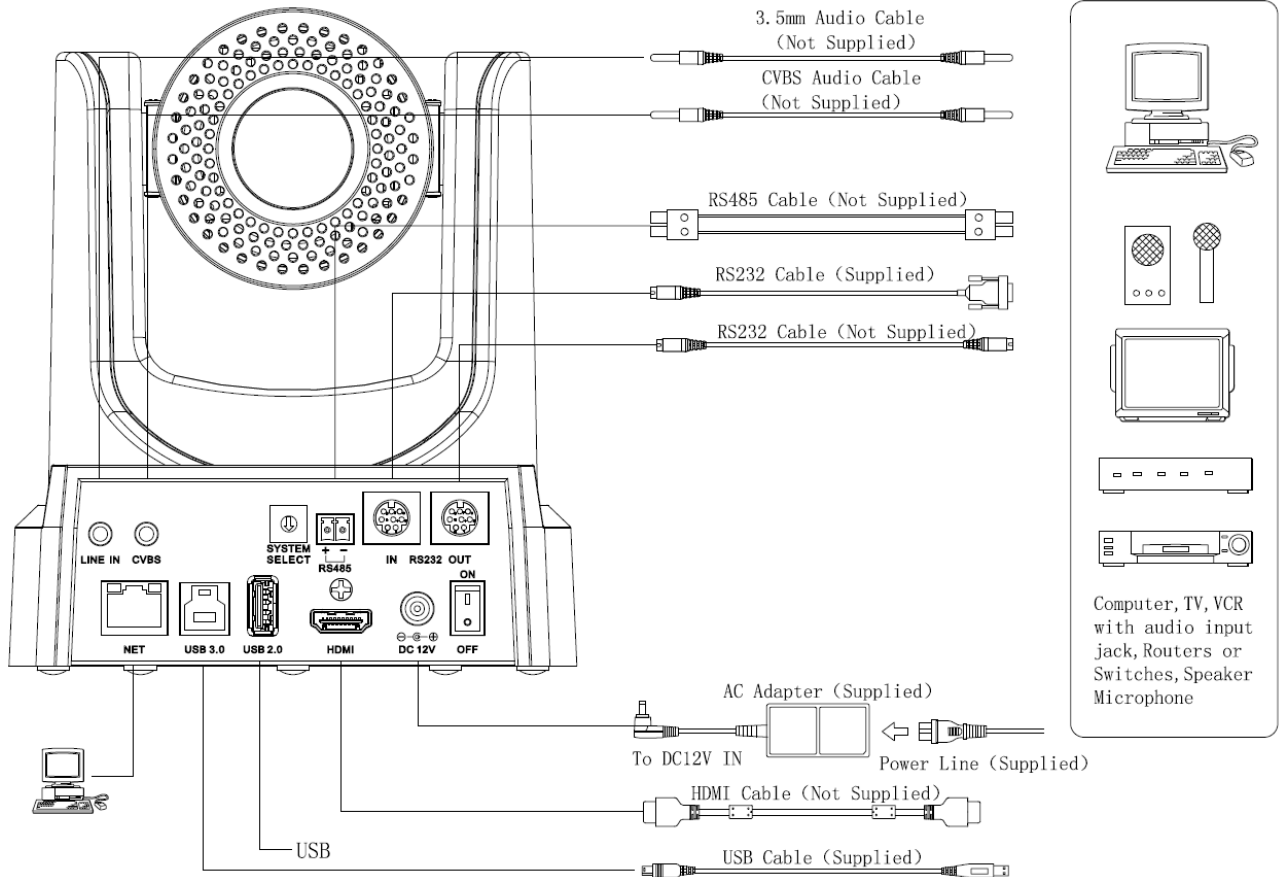

Step2. Setting of the system select switch

The option of video format:

VIDEO SYSTEM			
0	1080p60	8	720p30
1	1080p50	9	720p25
2	1080i60	A	-
3	1080i50	B	-
4	720p60	C	-
5	720p50	D	576i
6	1080p30	E	480i
7	1080p25	F	-

CAUTION:

- a. After changing the switch, you need to restart the camera to take effect.
- b. 720 p30 and 720 p25 only under the HDMI output.

Step3. Press the Switch ON/OFF button on the rear of the camera, the power lamp light.

Step4. Pan-Tilt will rotate to the maximum position of top right after the camera started, then it return to the center, the process of initialization is finished. (Note: If the position preset 0 has been stored, the position preset 0 will be called up after initialization)

Step5. (Optional) If you want to restore the factory default settings, Press [MENU] button to display the OSD menu. Select the item [MENU] -> [RESTORE DEFAULT] -> [Restore]. Set the value [Yes], press [HOME] button to restore the factory default settings.

RESTORE DEFAULT

▶ Restore Yes

◀▶ Change Value

[Home] OK

[Menu] Back

Features

- **72.5° Wide-angle Lens + 32x Digital Zoom**

Use 72.5° wide-angle high quality lens, support 12x optical zoom, and 32x digital zoom (optional)

- **USB3.0**

Support USB3.0 ultra-high speed interface, can transfer uncompressed original video, and downward compatible with USB2.0. USB3.0, HDMI, Network can output at the same time. It also support CVBS interface

- **Microphone & AAC Audio Encoding**

Built-in microphone, and support audio line in input. Support AAC audio encoding, better sound quality and smaller bandwidth

- **H.265 Support**

The first H.265 encoding support conference video camera in the world, enabling full HD 1080p/60fps video stream by ultra-low bandwidth.

- **1080P Full HD**

Apply Panasonic's 1/2.7 inch, 2.07 million effective pixels high quality HD CMOS sensor, can reach maximum 1920 x 1080 high resolution and achieve quality image.

- **Ultra-high Frame Rate**

The output frame rate up to 60fps in 1080P, up to 120fps output in 720P (supported by network only), 640x480P can be as high as 240fps (supported by network only, optional).

- **Face Detection**

Built-in face detection module, enabling PTZ tracking (optional).

- **Local Storage**

Support local storage module, directly recording to local USB flash disk without NVR.

- **Low-light**

High SNR of CMOS sensor combined with 2D and 3D noise reduction algorithm, effectively reduce the noise, even under low illumination conditions, picture can still keep clean and clear

- **Remote Control**

Using RS232/485 interface, all the parameters of the camera can be remote controlled by the high-speed communications.

Product Specification

Model	
Name	USB3.0 Type HD Color Video Camera
Camera	
Video System	HD: 1080p/60, 1080p/50, 1080i/60, 1080i/50, 1080p/30, 1080p/25, 720p/120 (supported by network only), 720p/60, 720p/50, 720p/30, 720p/25, 640x480p/240 (supported by network only, optional) SD: 480i, 576i
Sensor	1/2.7", CMOS, Effective Pixel: 2.07M
Scanning Mode	Progressive
Lens	12x, f3.5mm ~ 42.3mm, F1.8 ~ F2.8
Digital Zoom	32x (optional)
Minimal Illumination	0.05 Lux @ (F1.8, AGC ON)
Shutter	1/30s ~ 1/10000s
White Balance	Auto, Indoor, Outdoor, One Push, Manual
Backlight Compensation	Support
Digital Noise Reduction	2D&3D Digital Noise Reduction
Video S/N	≥55dB
Horizontal Angle of View	72.5 ° ~ 6.9 °
Vertical Angle of View	44.8 ° ~ 3.9 °
Horizontal Rotation Range	±170 °
Vertical Rotation Range	-30 ° ~ +90 °
Pan Speed Range	1.7 ° ~ 100 %s
Tilt Speed Range	1.7 ° ~ 69.9 %s
H & V Flip	Support
Image Freeze	Support

Face Detection	Support (optional)
Local Storage	Support
Number of Preset	255
Preset Accuracy	0.1 °
USB Featured	
Oprate System	Windows XP, Windows Vista, Windows 7,Windows 8,Mac OS X, Linux
Color System	YUV 4:2:2
Video format	USB3.0 : 1080p/60, 1080p/50, 1080p/30, 1080p/25, 720p/60, 720p/50, 720p/30, 720p/25
USB video communication protocol	UVC1.0
UVC PTZ	Support
IPC Features	
Video Compression	H.265/H.264/MJPEG
Video Stream	Main Stream, Sub Stream
Main Stream Resolution	1920x1080, 1280x720, 1024x576
Sub Stream Resolution	720x576, 720x480, 320x240
Video Bit Rate	128Kbps ~ 8192Kbps
Bit Rate Type	Variable Rate, Fixed Rate
Frame Rate	50Hz: 1fps ~ 50fps, 60Hz: 1fps ~ 60fps, 720p: 120fps, 640x480p: 240fps
Audio Compression	AAC
Audio Bit Rate	96Kbps, 128Kbps, 256Kbps
Support protocols	TCP/IP, HTTP, RTSP, RTMP, Onvif, DHCP, Multicast, etc.
Input/Output Interface	
HD Output	1xHDMI: Version 1.3
SD Output	1xCVBS: RCA jack, 1Vp-p, 75Ω
Network interface	1xRJ45: 10M/100M Adaptive Ethernet ports

Audio Input	1-ch: 3.5mm Audio Interface, Line In
USB	1xUSB3.0: Type B female jack
	1xUSB2.0: Type A female jack
Control Input/Output	1xRS-232: 8pin Min DIN, Max Distance: 30m, Protocol: VISCA/Pelco-D/Pelco-P
	1xRS-232 OUT: 8pin Min DIN, Max Distance: 30m, Protocol: VISCA network use only
	1xRS-485: 2pin phoenix port, Max Distance: 1200m, Protocol: VISCA/Pelco-D/Pelco-P
Power Connector	JEITA type (DC IN 12V)
Generic Specification	
Input Voltage	DC 12V
Current Consumption	1.0A (Max)
Operating Temperature	-5 °C ~ 40 °C
Storage Temperature	-20 °C ~ 60 °C
Power Consumption	12W (Max)
Dimensions	169mm x 142mm x 164mm
Weight	1.35Kg

Main Unit

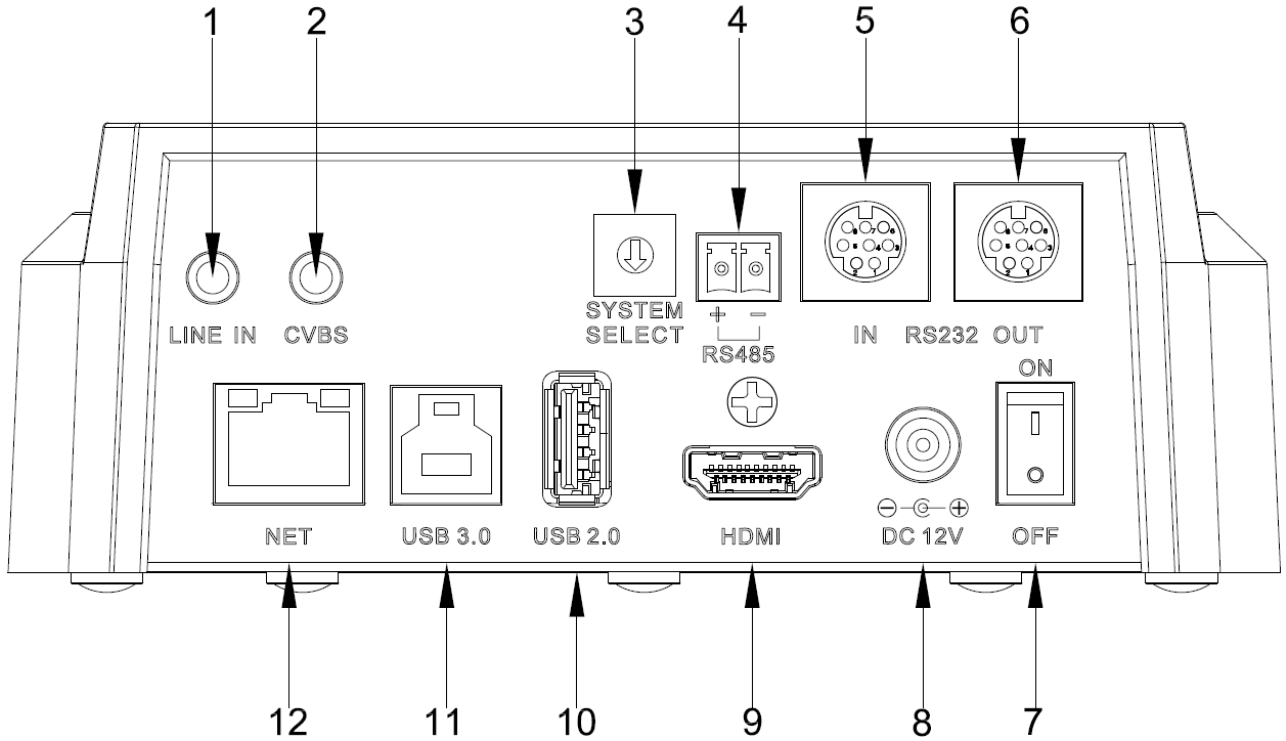

1. Line in Interface

2. CVBS Interface

3. System select switch

4. RS485 Interface

5. RS232 IN Interface

6. RS232 out Interface

7. POWER switch

8. DC IN 12V jack

9. HDMI interface

10. USB2.0

11. USB3.0

12. Rj45 interface

Size

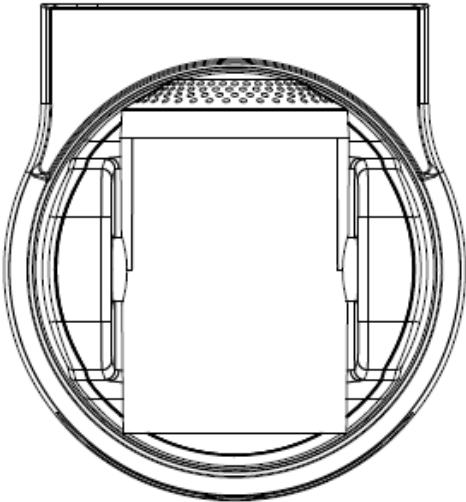
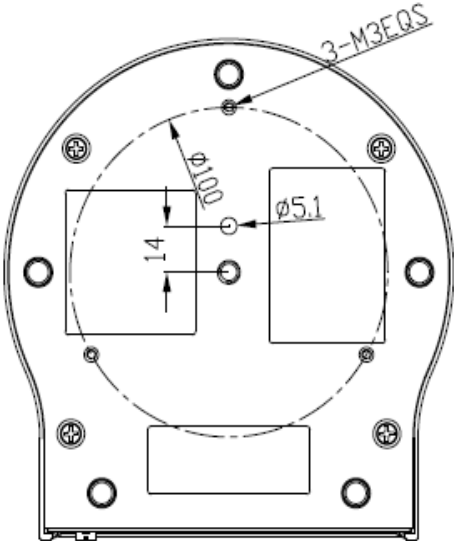
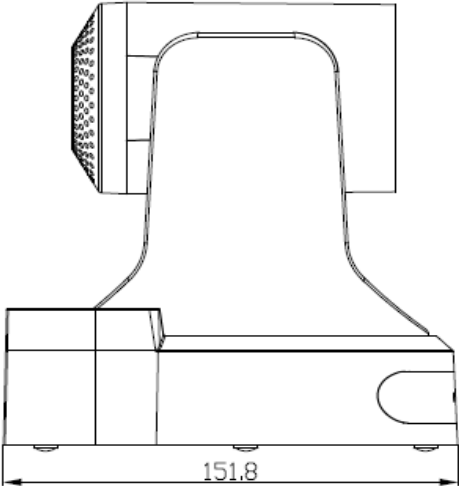
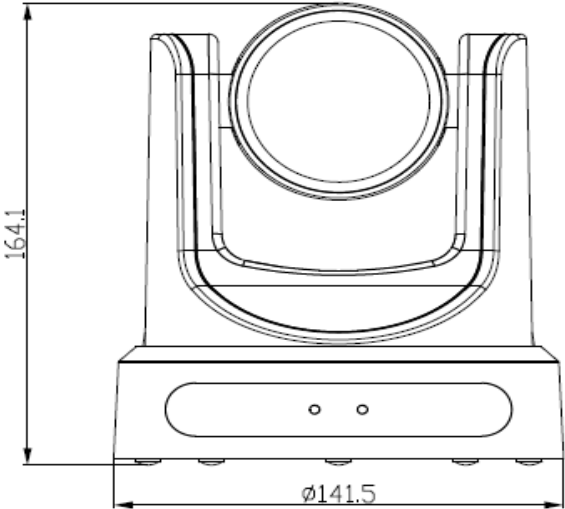

IR Remote Controller Explanation

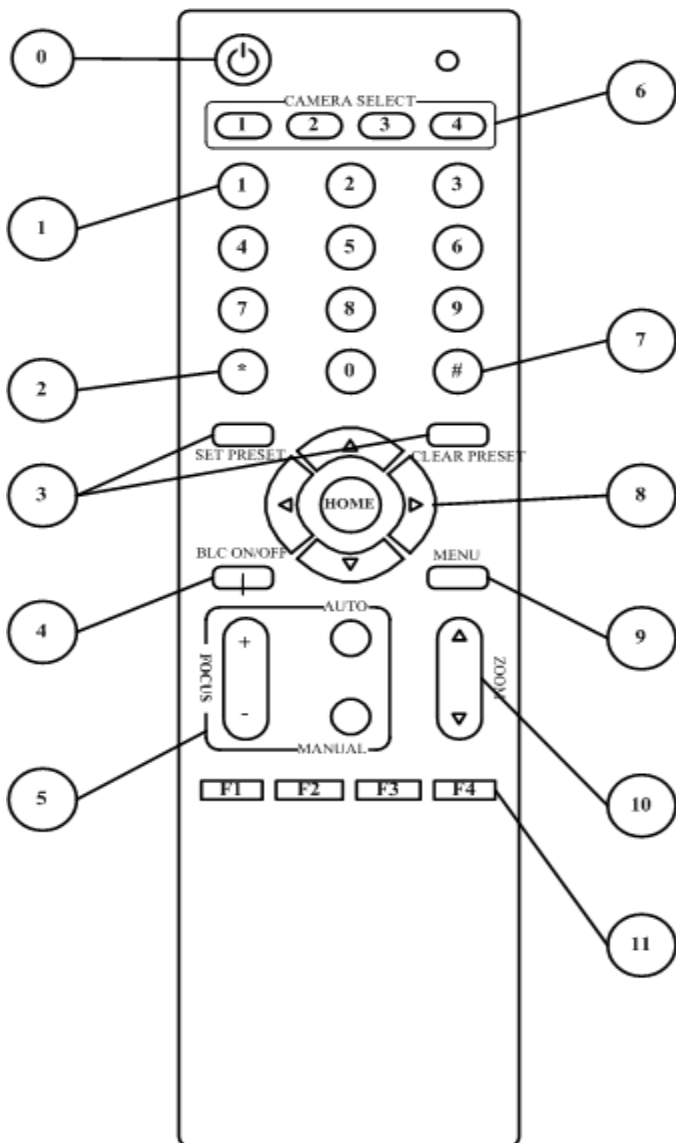

0. Standby Button

Press this button to enter standby mode. Press it again to enter normal mode.

(Note: Power consumption in standby mode is approximately half of the normal mode)

1. Position Buttons

To set preset or call preset

2. * Button

3. Set/Clear Preset Buttons

Set preset: Store a preset position

[SET PRESET] + Numeric button (0-9): Setting a corresponding numeric key preset position

Clear preset: Erase a preset position

[CLEAR PRESET] + Numeric button (0-9)

Or: [*]+[#]+[CLEAR PRESET]: Erase all the preset individually

4. BLC (Backlight Compensation) Button

BLC ON/OFF: Press this button to enable the backlight compensation. Press it again to disable the backlight compensation. (NOTE: Effective only in auto exposure mode)

Note: If a light behind the subject, the subject will

become dark. In this case, press the backlight ON / OFF button. To cancel this function, press the backlight ON / OFF button.

5. Focus Buttons

Used for focus adjustment.

Press [AUTO] adjust the focuses on the center of the object automatically. To adjust the focus manually, press the [MANUAL] button, and adjust it with [Focus +] (Focus on far object) and [Focus -] (Focus on near object)

6. Camera Select Buttons

Press the button corresponding to the camera you want to operate with the remote controller.

7. # Button

8. Pan/Tilt Control Buttons

Press arrow buttons to perform panning and tilting. Press [HOME] button to face the camera back to front

9. Menu Setting

Menu button: Press this button to enter or exit the OSD menu

10. Zoom Buttons

Zoom▲: Zoom In

Zoom▼: Zoom Out

11. Set Camera IR Address Buttons

[*]+[#]+[F1]: Address1

[*]+[#]+[F2]: Address2

[*]+[#]+[F3]: Address3

[*]+[#]+[F4]: Address4

12. Image freezing function

Open the freezing function after press [F4], display "Freeze" on the left upper corner character, after 5 seconds display disappear automatically. If you want to cancel the freeze, press [F4] key and then can return to normal, display "Unfreeze" on the left upper corner, after 5 seconds display disappear automatically.

USE IR Remote Controller

When the camera is working, you can use remote controller to perform panning, tilting, zooming and focusing, store and call back preset positions.

Button Instruction:

1. In this instruction, ‘press the button’ means the press and relax the two actions. Such as ‘press

[HOME] button’ means to press the [HOME] key and then relax action, and a special note will be given if a hold down for more than one second is required.

2. When a button-combination is required, do it in sequence. For example, ‘[*] + [#] + [F1]’ means press [*] first and then press [#] and press [F1] at last.

1. Pan/Tilt Control

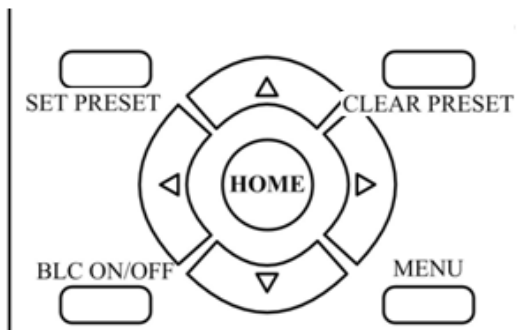

Move up: Press [▲]

Move down: Press [▼]

Move left: Press [◀]

Move right: Press [▶]

Face the camera back to front: Press [HOME]

Press and hold the up/down/left/right button, the camera will keep rotating from slow to fast, until it run to the mechanical limit; the camera stops as soon as the button is released.

2. Zoom

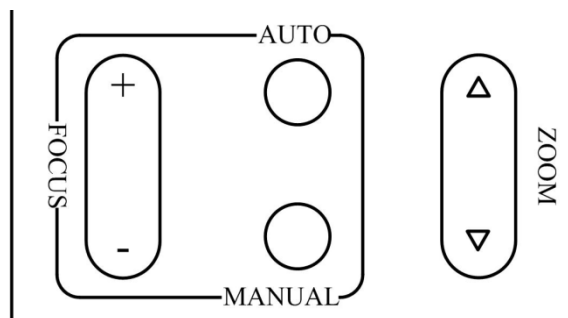

Zoom Out: press [ZOOM▼] button

Zoom In: press [ZOOM▲] button

Press and hold the button, the camera will keep zooming in or zooming out and it stops as soon as the button is released.

3. Focus Control

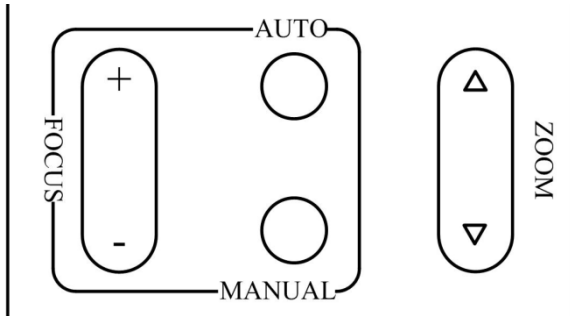

Focus Far: Press [FOCUS+] button (NOTE: Effective only in manual focus mode)

Focus Near: Press [FOCUS-] button (NOTE: Effective only in manual focus mode)

Press and hold the button, the action of focus continues and stops as soon as the button is released.

AUTO: Change focus mode to AF, adjusting the focus automatically.

MANUAL: Change focus mode to MF, adjusting the focus manually.

4. Backlight Switch



BLC ON/OFF: Press this button to enable the backlight compensation. Press it again to disable the backlight compensation. (Note: Backlight is only

effective in full auto exposure mode)

5. Presets Set/Clear

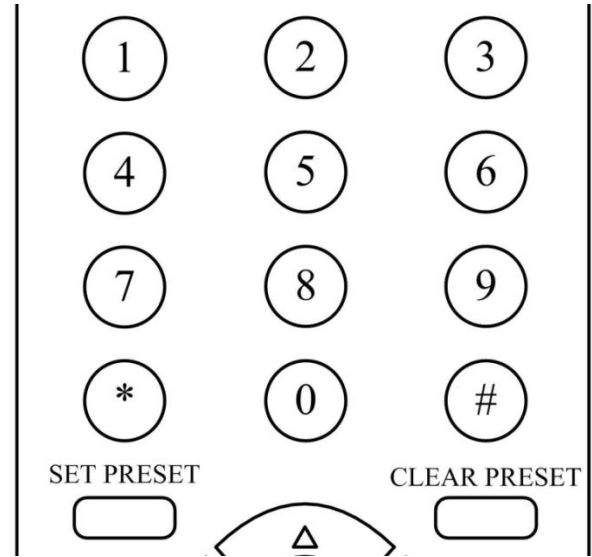

1. To store a preset position: The users should press the [SET PRESET] button first and then press the numeric button 0-9.

10 preset positions in total are available.

2. To erase the memory content of a preset position: The users should press the [CLEAR PRESET] button first and then press the numeric button 0-9.

Note:

Press [*]+[#]+[CLEAR PRESET] will erase all preset individually positions in the memory.

6. Recalling the Preset

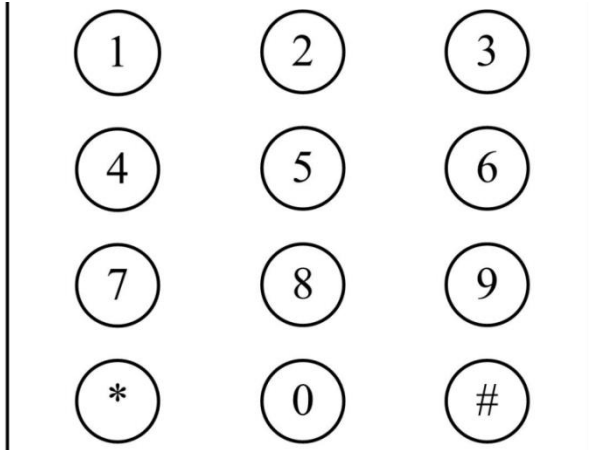

Press any of the numeric buttons 0-9 directly to recall stored preset positions and settings.

Note:

No action is executed if a relative preset position is not stored.

7. Camera Selection

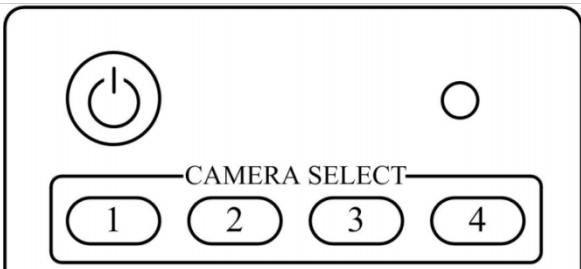

Press the button corresponding to the camera you want to operate.

8. Camera IR Address Set

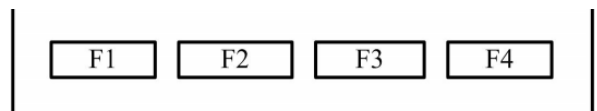

[*]+[#]+[F1]: Address1

[*]+[#]+[F2]: Address2

[*]+[#]+[F3]: Address3

[*]+[#]+[F4]: Address4

9. Shortcut Set

[*]+[#]+[1]: OSD menu default English

[*]+[#]+[3]: OSD menu default Chinese

[*]+[#]+[4]: Default IP address

[*]+[#]+[5]: Save OSD

[*]+[#]+[6]: Quickly recover the default

[*]+[#]+[7]: Display the manufacturer information

[*]+[#]+[8]: Look the camera version

[*]+[#]+[9]: Quickly set up inversion

RS-232 Interface

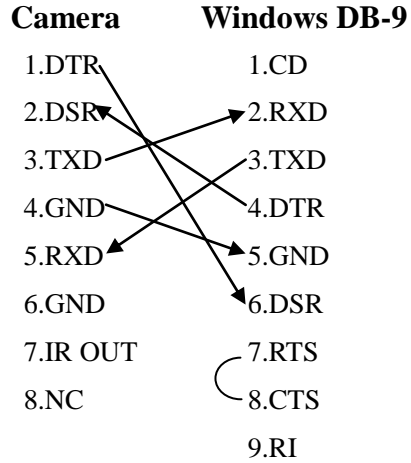
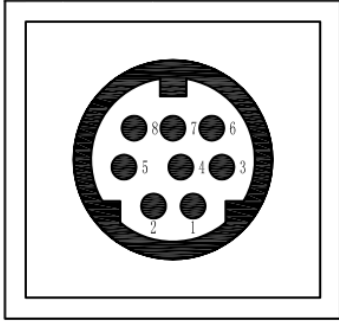

No.	Function
1	DTR
2	DSR
3	TXD
4	GND
5	RXD
6	GND
7	IR OUT
8	NC

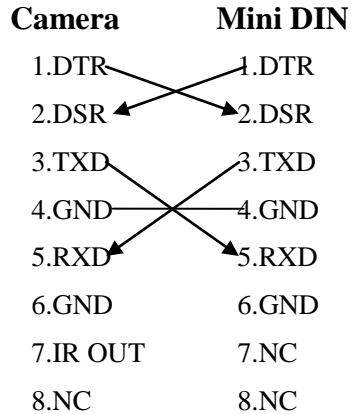

VISCA Network Configuration

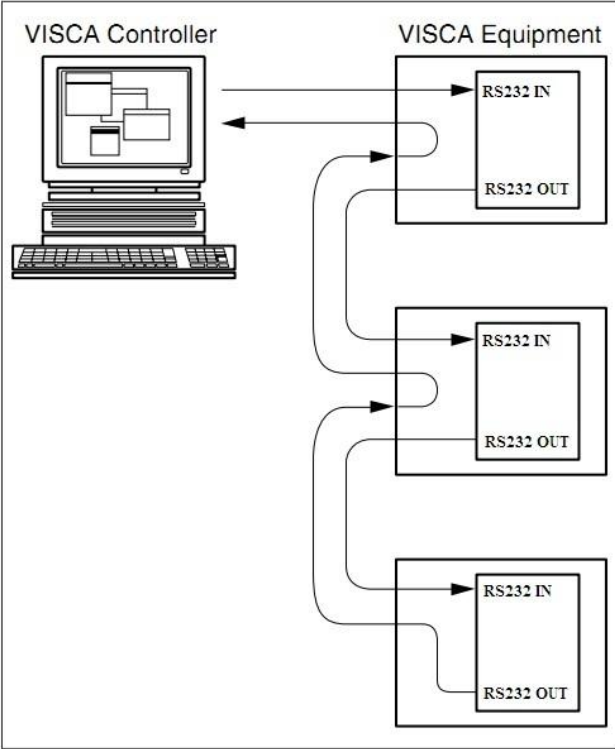

Serial Communication Control

In default working mode, the camera is able to connect to a VISCA controller with RS232C serial interface.

➤ RS232 Communication Control

The camera can be controlled via RS232 ,the parameters of RS232C are as follows:

Baud rate: 2400/4800/9600 bit/s.

Start bit: 1 bit.

Data bit: 8 bits.

Stop bit: 1bit.

Parity bit: none.

➤ RS485 Communication Control

The camera can be controlled via RS485, Half-duplex mode:

Baud rate: 2400/4800/9600 bit/s.

Start bit: 1 bit.

Data bit: 8 bits.

Stop bit: 1bit.

Parity bit: none.

Pan-Tilt will rotate to the maximum position of top right after the camera started, then it return to the center, the process of initialization is finished. (Note: If the position preset 0 has been stored, the position preset 0 will be called up after initialization) Then the users can control the camera with commands in the command list.

VISCA Command List

(Ignore)

Note:

The camera serial standard VISCA/Pelco-D/Pelco-P, if the need for the secondary development, According to standard protocol to control the camera. If you need VISCA/Pelco - D/Pelco - P protocol command list in detail, please contact the manufacturer.

Menu Setting

1. MENU

Press [MENU] button to display the main menu on the normal screen, using arrow button to move the cursor to the item to be set. Press the [HOME] button to enter the corresponding sub-menu.

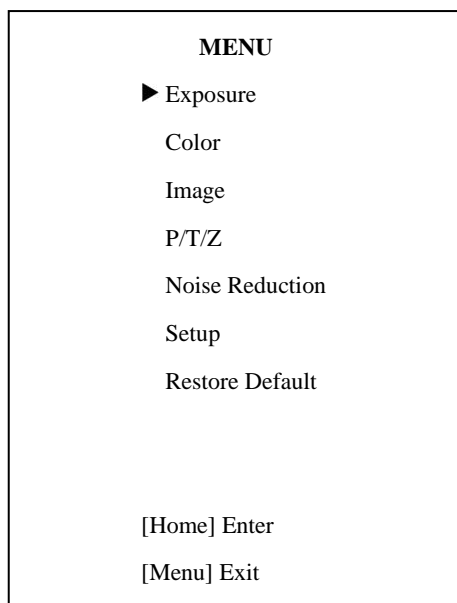

2. EXPOSURE

Move the cursor to the Exposure item in the main menu and press [home] button, EXPOSURE menu appears, as shown in the following figure.

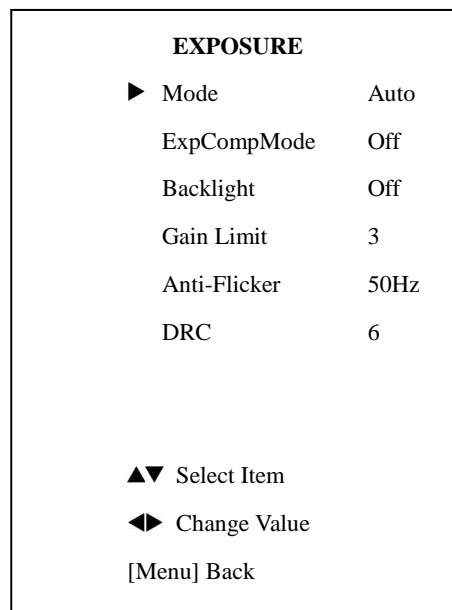

Mode: Exposure mode. Optional items: Auto, Manual, SAE, AAE, Bright

ExpCompMode: Exposure compensation mode, Optional items: On, Off (Effective only in Auto mode)

ExpComp: Exposure compensation value, Optional items: -7 ~ 7 (Effective only in ExpComp Mode item to On)

Gain Limit: Maximum gain limit. Optional items: 0 ~ 15 (Effective only in Auto, AAE, Bright mode)

Backlight: Set the backlight compensation,
Optional items: On, Off (Effective only in Auto mode)

DRC: DRC strength, Optional items: 0 ~ 8.

Bright: Intensity control, Optional items: 00~17.
(Effective only in Bright mode)

Anti-Flicker Flicker: Anti-flicker. Optional items:
Off, 50Hz, 60Hz (Effective only in Auto, Bright mode)

Iris: Aperture value. Optional items: F1.8,
F2.0,F2.4,F2.8,F3.4,F4.0,F4.8,F5.6,F6.8,F8.0,F9.6,F
11.0,Close (Effective only in Manual, AAE mode)

Shutt: Shutter value. Optional items: 1/30,1/60,
1/90,1/100,1/125,1/180,1/250,1/350,1/500,1/725,1/1
000,1/1500,1/2000,1/3000,1/4000,1/6000,1/10000
(Effective only in Manual, SAE mode)

3. COLOR

Move the cursor to the Color item in the main menu and press [home] button, COLOR menu appears, as shown in the following figure.

COLOR	
▶ WB Mode	Auto
Saturation	90%
Hue	7
AWB sens	Low

▲▼ Select Item
◀▶ Change Value
[Menu] Back

WB-Mode: White balance mode. Optional items:
Auto,3000K/Indoor,4000K,5000K/Outdoor,6500K-1
,6500K-2,6500K-3,One Push, Manual

RG: Red gain. Optional items: 0~255 (Effective only in Manual mode)

BG: Blue gain. Optional items: 0~255 (Effective only in Manual mode)

Sat.: Saturation. Optional items: 60% ~ 200%.

Hue: Chroma adjustment, Optional items:0 ~ 14

AWB sens: The white balance sensitivity,Optional items: Normal, High, Low.

4. IMAGE

Move the cursor to the Image item in the main menu and press [home] button, IMAGE menu appears, as shown in the following figure.

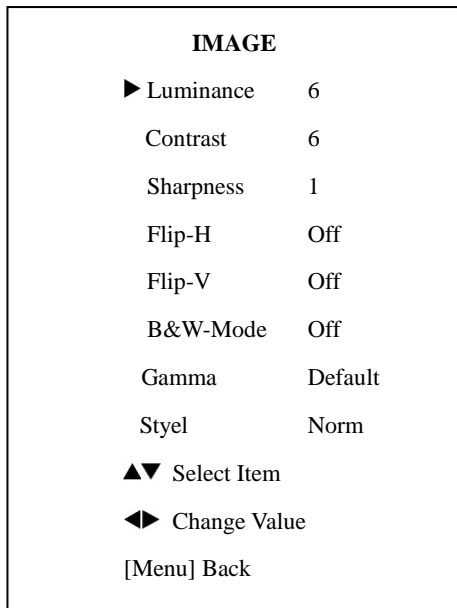

Luminance: Brightness adjustment. Optional items: 0 ~ 14

Contrast: Contrast adjustment. Optional items: 0 ~ 14

Sharpness: Sharpness adjustment. Optional items: Auto, 0 ~ 15

Flip-H: Image flipped horizontally. Optional items: On, Off.

Flip-V: Image Flip Vertical. Optional items:

On, Off

B&W-Mode: Image color. Optional items: On, Off

Gamma: Optional items: Default, 0.45, 0.5, 0.56, 0.63

Style: Optional items: Norm, Clarity, Bright, Soft.

5. P/T/Z

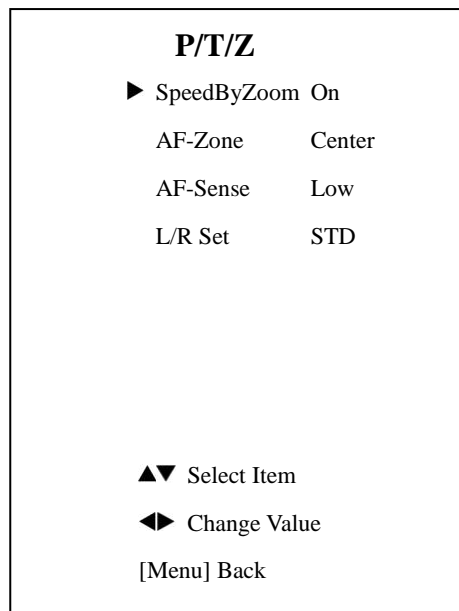

SpeedByZoom: The depth of field scale switch, Optional items: On, Off

AF-Zone: Interested in focusing area, Optional items: Top, Center, Bottom

AF-Sense: Automatic focusing sensitivity options, Optional items: Low, Normal, High
L/R Set: Optional items: STD, REV

6. NOISE REDUCTION

Move the cursor to the Noise Reduction item in the main menu and press [home] button, NOISE REDUCTION menu appears, as shown in the following figure.

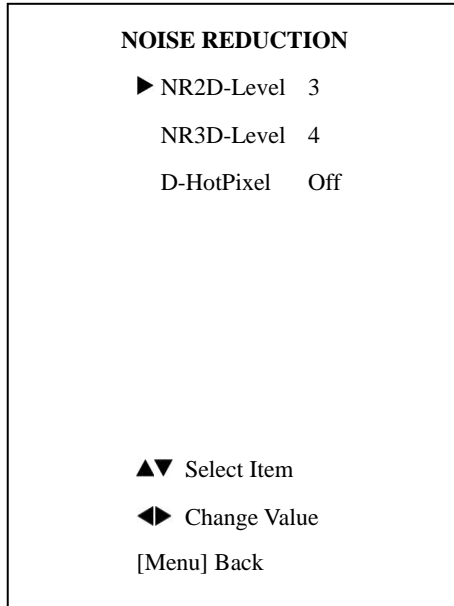

NR2D-Level: 2D noise reduction. Optional items: Off, Auto, 1 ~ 5

NR3D-Level: 3D noise reduction. Optional items:

Off, 1 ~ 8

D-HotPixel: Dynamic bad points, Optional items: Off, 1 ~ 5

7. SETUP

Move the cursor to the Setup item in the main menu and press [home] button, SETUP menu appears, as shown in the following figure.

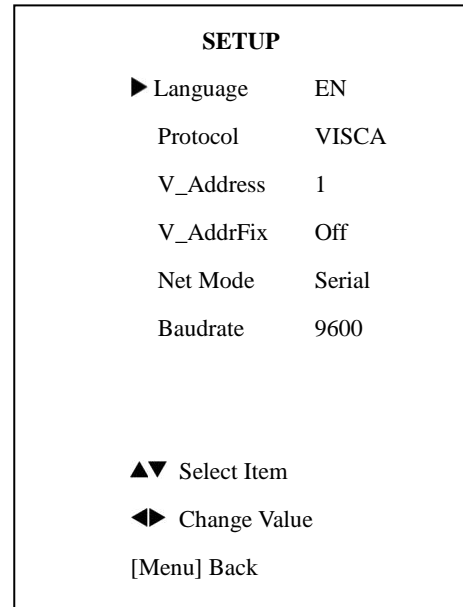

Language: menu language, Optional items: EN, Chinese, Russian

Protocol: Control protocol type. Optional items: AUTO, VISCA, PELCO-D, PELCO-P

V_Address: Protocol address, To be decided

according to the agreement, AUTO, VISCA protocol

Optional items: 1 ~ 7

P_D_Address: PELCO-D protocol Optional items:
0 ~ 254

P_P_Address: PELCO-P protocol Optional items:
0 ~ 31

V_AddrFix: If I can change through the serial port
of infrared switch, Optional items: On, Off (When
set to On, useless in 88 30 01 FF Command)

Net Mode: Set the serial port control networking,
Optional items: Serial, Paral

Baudrate: Serial port baud rate. Optional items:
2400, 4800, 9600

8. RESTORE DEFAULT

Move the cursor to the Restore Default item in the
main menu and press [home] button, RESTORE
DEFAULT menu appears, as shown in the following
figure.

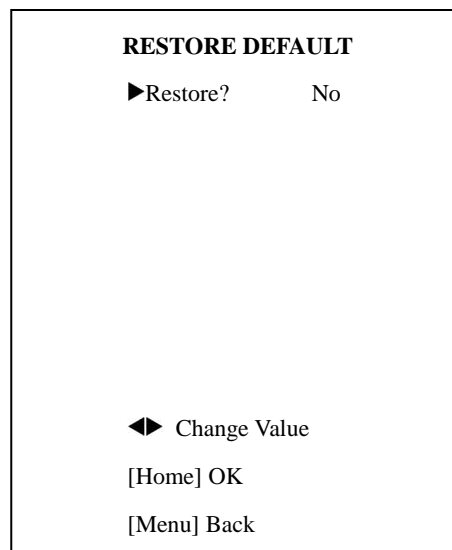

Restore: Confirm restore factory settings.

Optional items: Yes, No

Note: Press [HOME] button to confirm, All
parameter restore default, Include IR Remote
address and VISICA Address

Save: Save Options. Optional items: Yes, No

Internet connection(Only the network models)

1 Operating Environment

Operating System: Windows 2000/2003/XP/vista/7/8

Network Protocol: TCP/IP

Client PC: P4/128MRAM/40GHD/ support scaled graphics card, support DirectX8.0 or more advanced version.

2 Equipment Installation

- 1) Connect internet camera to your internet or to your PC directly via internet cable.
- 2) Turn on DC12V power.
- 3) The orange light of internet port lit on, green light flashing, and the physical connection finished.

3 Internet Connection

Connection ways between internet camera and computer, as picture 1.1 and picture 1.2 shown:

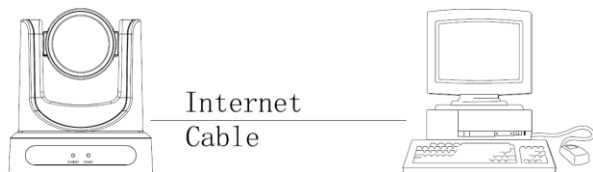

Picture 1.1 connect by internet cable

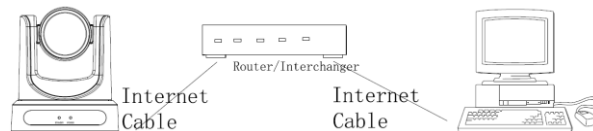

Picture 1.2 Connect by router /interchanger

4 IP camera visited/ controlled by LAN

4.1 Setup IP address

IP camera default IP address"192.168.100.88",
Unknow camera IP, view as below:

Method 1: press * and # and 4 on remote controller one by one, the camera IP address will be shown on screen.

Method 2: connect camera to PC with ethernet cable, use "upgrade_En.exe" to search for IP address



Change IP address,2 methods as below:

Method 1: On web control page, find "Network"--->Change IP---->Click "Apply"---->Restart camera

Lan Settings

IP Configuration Type: Fixed IP Address

IP Address: 192.168.100.88

Subnet Mask: 255.255.255.0

Gateway: 192.168.100.1

DNS Address: 192.168.100.1

MAC Address: D4 : E0 : 8E : DB : 18 : 06

Port Settings

HTTP Port number: 80 (80)

RTSP Port: 554 (554)

PTZ Port: 5678 (5678)

Control Protocol Settings

Visca Address: 1 (1~7)

Pelco-D Address: 0 (0~255)

Pelco-P Address: 0 (0~31)

RTMP Settings

First stream: On Off Video Audio

MRL: rtmp://192.168.100.138/live/stream0

Second stream: On Off Video Audio

MRL: rtmp://192.168.100.138/live/stream1

RTSP Settings

RTSP Auth: On Off

ONVIF Setting

ONVIF: On Off

ONVIF Auth: On Off

Multicast Settings

Multicast: On Off

Address: 224.1.2.3

Port: 6688

Apply Cancel

Method 2: Open “upgrade_En.exe”, change IP and click “Set”. After modified, IP Camera be restart.

UPGRADE v1.9

Search Upgrade Config Backup

Mode: Manual

IP Address: 192.168.100.88

Mask: 255.255.255.0

GateWay: 192.168.100.1

First DNS: 192.168.100.1

MAC Address: D4 : E0 : 8E : DB : 18 : 06

Set Reset

Language: English



NOTE!

IP camera default IP address "192.168.100.88", user "admin", password "admin".

4.2 Visit/Access IP Camera

Input http://192.168.100.88 to IE (better With IE web browser, others will cause little latency), a login window pop up, input login name: admin, password: admin, shown as below:



After login, shown as below:



 **NOTE!**

If user first time use this camera by internet (only for new user), must install a player software (VLC). Please go to VLC webside <http://www.videolan.org/vlc/download> and Install VLC (player software). After installation, login again,will show as above:

5 IP Camera accessed/controlled by WAN (internet)

5.1 Setup IPC accessed/controlled by dynamic DNS

2 dynamic DNS available:

Dyndns.org,
3322.org

Router Port Mapping:

Take TP-LINK router for example, enter Router Home Page (interface page),select "Transit control"--"Transit rule"--"Virtual server"-- "Virtual service" ,add a new port number in "Outside Port" ,add a new port number in "inside port", put camera IP address to "IP address", then select "Apply" and "Add", shown as below: (sorry, we do not have English Version TP-Link here, so put the Chinese Version picture for reference, the position is the same)

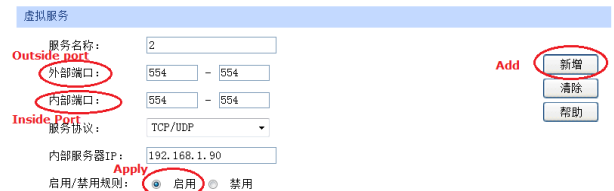

虚拟服务

服务名称:

外部端口: -

内部端口: -

服务协议:

内部服务器IP:

启用/禁用规则: 启用 禁用

新增 清除 帮助

选择	序号	服务名称	服务协议	外部端口	内部端口	内部服务器IP	状态	设置
<input type="checkbox"/>	1	2	TCP/UDP	554	554	192.168.1.90	已启用	
<input type="checkbox"/>	2	1	TCP/UDP	88	80	192.168.1.89	已启用	
<input type="checkbox"/>	3	3	TCP/UDP	89	80	192.168.1.90	已启用	

5.2 Dynamic DNS visit camera

Set domain name to camera, setup the parameter, then dynamic DNS can access camera. Access link: <http://hostname:port number> For example, setup host computer name: youdomain.f3322.org, camera port number: 554, Access link should be: <http://youdomain.3322.org:554>.



NOTE!

If camera port default as 80, then unnecessary to input port number, use host name can access camera directly .

5.3 VLC stream media player monitoring

Visit VLC media server procedure

Open VLC media player, click "Media"->"Open Network Steam", or click "Ctrl+N"; as below:

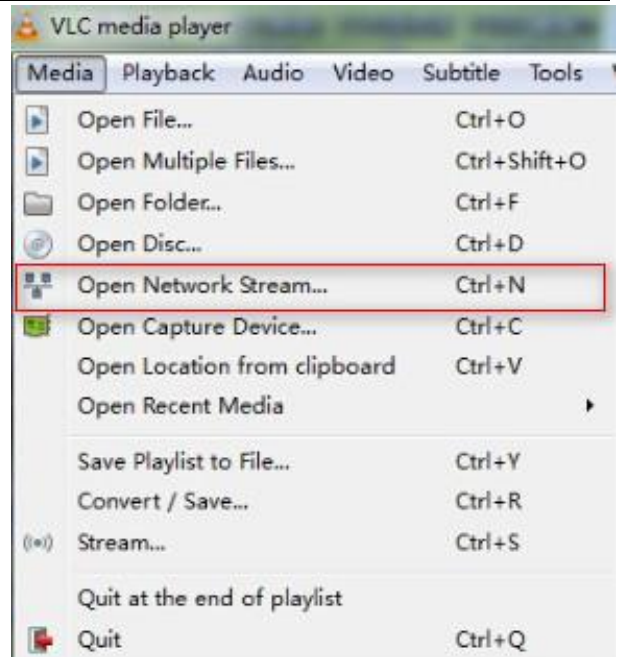

Input URL address:

rtsp://ip: port number/1 (Main stream);

rtsp://ip: port number/2 (Sub stream).



NOTE!

RTSP port number default 554.

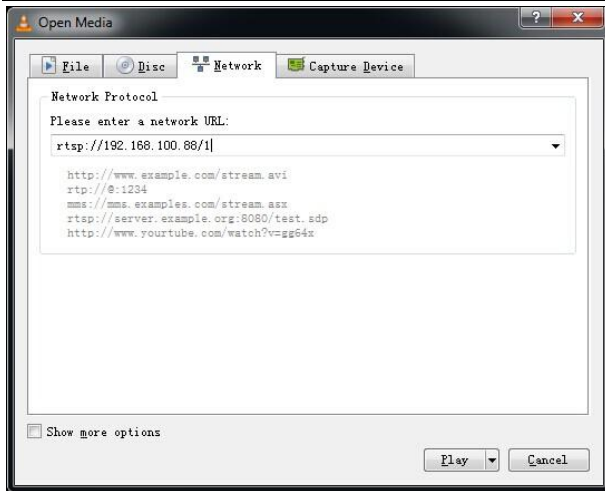

6 IP Camera parameter setup

6.1 Homepage introduction

Menu

All pages include 2 menu bars:

Real time monitoring: displaying video image

Parameter setup: with function buttons

A. Video viewing window

Video viewing window must be same as video resolution, the bigger the resolution is, the bigger the playing area is. Double click viewing window, will show full-screen, double click again, will return to initialized size.

Status bar in viewing window shown as below



- 1) Video playback pause button: control real-time video pause, stop the last picture, click recoverable video again.
- 2) Audio control buttons: can set silent mode.
- 3) Full screen switch button.

B. PTZ Setup

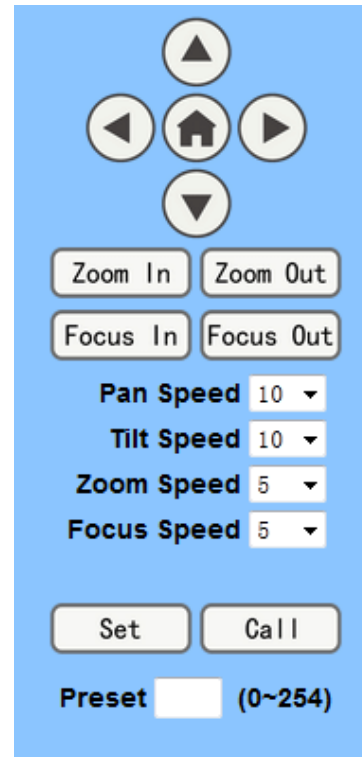

- 1) PTZ direction control box: Up, down, left, right, home oblique button as above

- 2) Rate: Vertical speed can be chosen as 1 ~ 24, horizontal direction at the rate of 1 ~ 20.
- 3) select corresponding speed and click direction button to realize PTZ speed up or speed down.
- 4) Zoom In/Zoom out: for zooming in or zooming out, Focus In/ Focus Out: Focusing on distant objects or Focusing on close objects.
- 5) Set/Call: When PTZ turn to expected position, can set up a number of preset that user want. click "Set" button, when PTZ turn to other position, click "Call" button, PTZ turn back to preset position.

C. Language selection

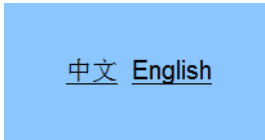

Chinese/English

6.2 Media

Video Setup, please click "Video"

Video Settings

Video Format: Dial Priority

Encode Protocol: H264

Encode Level: mainprofile

First stream

Resolution: 1920x1080

Bit Rate: 4096 (32~8192) kbps

Frame Rate: 30 fps

I Key Frame Interval: 30 (2~150)

Bit Rate Control: CBR VBR

Fluctuate Level: 1

Second stream

Resolution: 320x240

Bit Rate: 1024 (32~6144) kbps

Frame Rate: 30 fps

I Key Frame Interval: 30 (2~150)

Bit Rate Control: CBR VBR

Fluctuate Level: 1

Apply
Cancel

1) Video format

Support 50HZ(PAL)and 60HZ(NTSC), and Dial priority three formats.

2) Encode Protocot

Support H.264 and H.265 two formats.

3) Encode Level

Support baseline, mainprofile, highprofile

three formats.

4) Resolution

Main bit flow support 1920x1080, 1280x720, 1024x576 minor bit flow support 720x480, 720x576, 320x240, the bigger resolution is, the clearer the image will be, more network bandwidth will be taken.

5) Bit Rate

User can assign bit flow/stream, normally speaking, the bigger bit flow is, the clearer the image will be. The bit allocation must combine with network bandwidth, when the network bandwidth is too narrow and the allocated bit flow is too big, will cause video signal flow not to be transmitted normally, the video effect will be worse.

6) Frame rate

User can specify the size of the frame rate, generally, the frame rate greater, the image more smooth; Frame rate is smaller, the more sense of beating.

7) I key frame interval:

Set interval between 2 I frame, the bigger interval is, the response will be lower from viewing window.

8) Bit Rate control

Code stream control way:

Constant bit rate: video coder will be coding according to preset speed

Variable bit rate: video coder will adjust the speed based on preset speed to gain the best image quality.

9) Fluctuate level

Restrain the fluctuation magnitude of variable rate, grade 1 ~ 6

6.3 Image Setup, please click “Image”



1) Brightness

Image bright 0~14, slider control, on the right

shows the corresponding numerical. Default 6.

2) Saturation

Saturation 0~14, slider control, on the right shows the corresponding numerical. Default 3.

3) Contrast

Contrast 0~14, slider control, on the right shows the corresponding numerical. Default 6.

4) Sharpness

Sharpness 0~15, slider control, on the right shows the corresponding numerical. Default 1.

5) Hue

Hue 0~14, slider control, on the right shows the corresponding numerical. Default 7.

6) Flip & Mirror

Tick Flip to realize image upside down, tick mirror to realize image around the mirror. Default not tick.

7) Button

Adjusting the parameters, press "apply" button to save, press "cancel" button to cancel the adjustment of the parameters, press "default" button obtain the default value.

6.4 Audio Setup, please click "Audio"

Audio Settings

Audio Type: AAC ▾

Sample Rate: 48K ▾

Bit Rate: 96K ▾

Input Type: Line in ▾

Input Vol L : 0 (-97~30) db

Input Vol R : 0 (-97~30) db

Apply Cancel

1) Audio Type

Audio type AAC

2) Sample rate

Sample rate 44.1 K and 48 K, selectable.

3) Bit rate

Bit rate 96k, 128k, 256k, selectable

4) Input Type

line in only

5) Input VolL

The volume of the left channel

6) Input VolR

The volume of the right channel

7) Button

Press "apply" button to save parameters, press "cancel" button to cancel parameter

6.5 System Setting, please click “System”

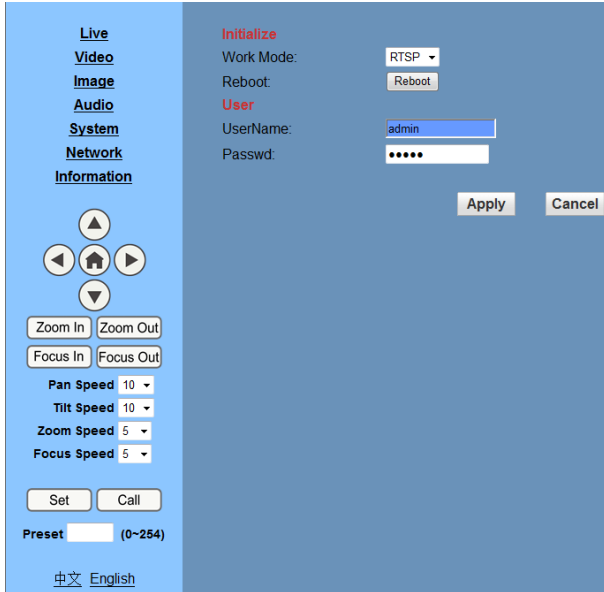

1) Work Mode

Work Mode RTSP

2) Reboot

Click the "Reboot" button, system restart.

3) User and password

The user can modify the password (letters and Numbers only)

4) Apply / Cancel

Modify password and click the "apply" button to the login page, press "cancel" button to cancel password change.

6.6 Network Setting, please click “Network”

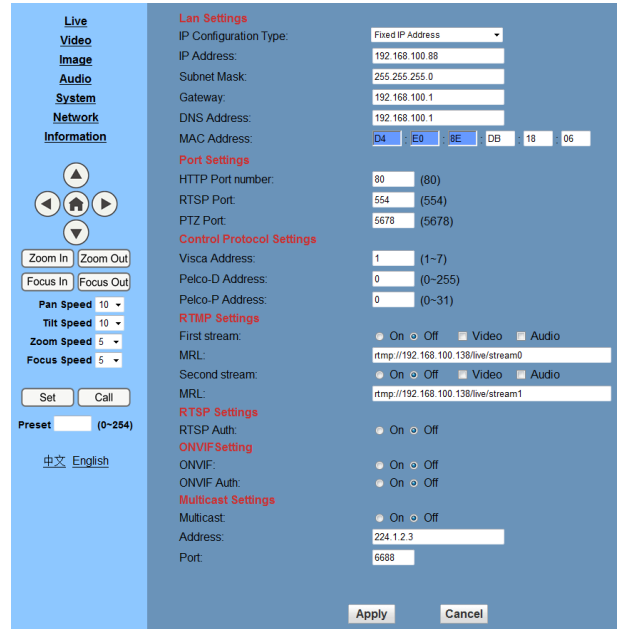

1) Lan Settings

Default the IP address is 192.168.100.88, The MAC address can be modified.

2) Port Settings

A. HTTP Port

IP address identifies the network device, the device can run multiple web applications, each network program using network port to transmit data, so data transmission to be carried out between the port and port. Port setting is to set up WEB SERVER program using which port to transmit.

When port mapping, need to be consistent with the port number(default port: 80)

B. RTSP Port

Network camera support RTSP protocol, use the VLC tools broadcast.

C. PTZ Port

Support PTZ protocol, default port: 5678.

3) Control Protocol Setting

Setting camera control communication protocol, include Visca address, Pelco-D address, Pelco-P address.

4) RTMP Setting

Setting the camera stream, can set up two stream, in the two stream selection control code stream of "On", "Off", "Video", "Audio", etc.

5) RTSP Setting

Setting network camera rtsp protocol of "On", "Off".

6) ONVIF Setting

Setting the ONVIF protocol and ONVIF authorization "On", "Off".

7) Multicast Setting

Setting multicast "On", "Off", and multicast address(default address 224.1.2.3)and port(default 6688)

8) Apply / Cancel

Modify network parameters then press "Apply" button to modify network parameters, press "Cancel" button to cancel network parameters.

6.7 Device Information, please click "information"

Show the current device information, as shown below.

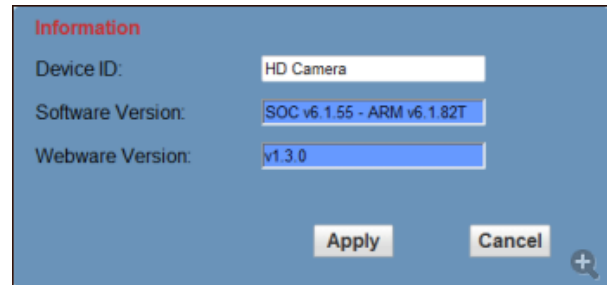

Note:

Software version may not be the latest version of the current, please release version shall prevail.

7 Download the Network upgrade program

If you need the camera upgrade program, please contact the manufacturer.

USB3.0

Camera support UVC protocol, compatible USB2.0 & USB3.0.

USB3.0 support 1920x1080p/60 max output.

USB3.0 support 960x540p/60 max output.

Support OS

Windows XP/2003/VISTA/7/8 and other system、Linux、Mac OS

General software

Windows: AMCAP, VLC, Debut Video Capture, etc.

Linux: V412 software driver and VLC media player, etc.

Mac OS: FaceTime, iChat, Photo Booth and Debut Video Capture, etc.

Notice:

Recommend making AMCAP version 8.0 in Windows, which software performance is more relatively stable.

When using high version of AMCAP in low configuration system, it will make the stream rendering slow.



NOTE!

When camera first time accessed by USB cable, must install plug-in.

Setting of the system select switch to select USB resolution, operation method, please refer to article 3 of “quick start”.

Maintenance and Troubleshooting

Camera Maintains

- If camera will not be used for a long time, please turn off the power switch, disconnect AC power cord of AC adaptor to the outlet.
- Use soft cloth or tissue to clean the camera cover.
- Please use the soft dry cloth to clean the lens. If the camera is very dirty, clean it with diluted neuter detergent. Do not use any type of solvents, which may damages the surface.

Unqualified Application

- No shooting extreme bright object for a long period of time, such as sunlight, light sources, etc.
- No operating in unstable lighting conditions, otherwise image will be flickering.
- No operating close to powerful electromagnetic radiation, such as TV or radio transmitters, etc.

Troubleshooting

Image

- No image
 1. Check whether the power cord is connected, voltage is OK, POWER lamp is light.
 2. Check whether the camera can self-test after startup.
 3. Check the BOTTOM switch and make sure the two switches are both set OFF.
 4. Check video cable is connected correctly.
- Abnormal display of image

Check video cable is connected correctly.
- Image dithering even at widest zoom position
 1. Check whether camera is fixed correctly.
 2. Make sure if there are something like vibration machine or other things nearby.
- IE browser not video image IE

When IPC first time accessed by Internet Explore (IE or other web browser), must install plug-in.

User first time use this camera by internet (only for new user), must install a player software (VLC).

Please go to VLC website <http://www.videolan.org/vlc/download> and Install VLC (player software).

After installation, login again, will show image, the video image is displayed.

- Unable to access IP Camera by IE browser.
 1. Access to the network with PC can test whether network works, in this way to get rid of cable failure, network failure caused by PC virus until the PC can be Ping.
 2. Disconnect IP Camera with network, IP Camera and PC are connected, according to the proper operations to re-set the IP address.
 3. Check the server's IP address and subnet mask and gateway address.
 4. MAC addresses conflict.
 5. Web port is occupied by other devices.
- When modify IP address in an incorrect way cause the wrong IP address or forget web passwords, press the IR remote controller "[*]+[#]+[Manual]" to restore the default value (Default IP: 192.168.100.88 Default username: admin Default password: admin)

Control

- IR remote controller cannot control the camera
 1. Change the battery
 2. Check the camera working mode.
 3. Check IR address of the Remote Commander is set correctly.
- Serial communication cannot control the camera
 1. Check the camera working mode.
 2. Check control cable is connected correctly.

Copyright Notice

All contents of this manual, whose copyright belongs to our Corporation. Cannot be cloned, copied or translated without the permission of the company. Product specifications and information which were referred to in this document are for reference only, and the content will be updated at any time without prior notice

2015/9